



Unified MailCall

Installation Guide

© 2003 Domino Telecom Solutions.

All rights reserved.

Second edition 2003.

PhoneSoft is a trademark of Domino Telecom Solutions.

RealSpeak is a trademark of ScanSoft Inc. and is used here under license.

DECTalk is a trademark of Fonix Corporation.

Protected by one or more of the following United States patents: 5,070,526; 5,434,906; 5,488,650; 5,533,102; 5,568,540; 5,581,604; 5,625,676; 5,651,054; 5,940,488; 6,041,114. Additional U.S. and foreign patents pending.

Domino Telecom Solutions.

www.phonesoft.com

TABLE OF CONTENTS

About this guide	5
Installation overview	6
Installing voice boards	9
Setting up the voice boards	11
Setting up the phone system	14
Installing and starting Unified Messaging	18
Changing Unified Messaging default settings	20
Setting up users	24
Setting up phone lines	30
Installing RealSpeak	31
Installing additional languages	32
Setting up Play By Phone and Play Multimedia	34
Troubleshooting read and unread messages.....	37
Appendix	
Proline 2V voice board	42
Dialogic D/41H ISA voice board.....	44
Dialogic D/41E PCI voice board	46
Dialogic D/41ESC voice board.....	48
Dialogic D/120JCT-LS voice board	50
Dialogic D/160SC-LS voice board	52
Dialogic D/240PCI-T1 voice board	55

About this guide

The *PhoneSoft™ Unified Messaging Trial Software Installation Guide* contains instructions for installing and setting up Unified Messaging Trial Software. The latest version of this guide can be found at: <http://www.activevoice.com/products/phonesoft/>.

The guide focuses on Unified Messaging Trial Software. For extensive information about the installation, setup and use of third-party software and hardware, refer to the manufacturer's documentation.

For information on using Unified Messaging Trial Software, please refer to the *User Guide*.

Documentation conventions

The guide uses the following conventions:

User Input Information that the user types appears in Courier: tedit

Key names Key names appear in capital letters: ENTER.

Cascading selections The “>” symbol separates the selections you make: on menus (Programs > Dialogic System Software > Configuration Manager); in the navigation levels of Unified Messaging Trial Software; and in menu trees.

Installation overview

The following steps offer general guidelines for setting up a new version of Unified Messaging Trial Software.

Setup steps

- 1 Confirm the minimum system requirements.**
See “Minimum system requirements” on page 8.
- 2 Collect all installation checklist components.**
See “Installation checklist” on page 8.
- 3 Install voice boards.**
See “Installing voice boards” on page 10.
- 4 Set up the phone system integration.**
See “Setting up the phone system” on page 15.
- 5 Install Unified Messaging Trial Software.**
See “Installing and starting Unified Messaging Trial Software” on page 19.
- 6 Set up Unified Messaging Trial Software.**
See “Changing default settings” on page 21, “Setting up users” on page 25 and “Setting up phone lines” on page 32.
- 7 Install optional Unified Messaging Trial Software packages.**
See “Installing RealSpeak” on page 33, “Installing additional languages” on page 34 and “Setting up Play By Phone and Play Multimedia” on page 36.
- 8 Customize automated attendant.**
See the *PhoneSoft Software Development Kit User Guide* for details.
- 9 Using Soft Phone with the trial software**

Upgrading from E-Mail Reader to Unified Messaging Trial Software

To upgrade from E-Mail Reader to the latest version of Unified Messaging Trial Software, use the Windows NT or Windows 2000 Uninstall program to uninstall E-Mail Reader and then follow the Setup steps above to install Unified Messaging Trial Software.

E-Mail Reader and Unified Messaging Trial Software have a few shared settings that may already be set up for E-Mail Reader. When you find fields or procedure steps that are already set up or done, you can skip them and go to the next installation step.

Installation requirements and checklist

Minimum system requirements

- Pentium III 600 MHz (or higher) computer with a CD-ROM drive and monitor.
- Windows 95, 98, ME, NT 4.0 with Service Pack 3 (or higher) or Windows 2000 Server.
- 128MB of RAM.
- 100 MB of available hard disk space.
- Lotus Notes client or Domino server version 4.6 or higher software, which is installed and set up on the computer.
- The computer's system path contains the Notes or Domino directory. To confirm and set up the path, see "To confirm the system path exists" on page 9.
- An available ISA or PCI computer slot.
- At least one ISA or PCI voice board that corresponds with the available slot.
- Unified Messaging Trial Software can be installed on either a Notes client computer or a Domino server. For systems with:
 - Less than 16 ports, you can run Unified Messaging Trial Software on the same computer as the Domino server that stores the applicable databases.
 - 16 or more ports, run Unified Messaging Trial Software on a separate dedicated Notes client computer that is connected to the applicable Domino server.

NOTES: Additional memory may increase performance. If you are running other applications on the same computer, 128 MB of RAM may be needed.

Installation checklist

- Computer that meets the minimum system requirements.
- Unified Messaging Trial Software software and documentation.
- License diskette, which contains the license file that you receive from your sales representative. This file is not available on the Internet.
- Password that is in the Readme file on the license diskette.

To confirm the system path exists

- 1 At a DOS prompt on the Unified Messaging Trial Software computer, type notes and press ENTER.
- 2 If Notes or Domino start, the path exists. If Notes or Domino does not start, perform one of the following three procedures, as appropriate.

To set up the computer's system path for Windows NT

- 1 From the Start menu on the Unified Messaging Trial Software computer, select Settings>Control Panel and then double-click "System."
- 2 In the System Properties dialog box, select the Environment tab.
- 3 In the System Variables list, locate and select "Path."
- 4 In the value field, select and go to the end of the value and type a semicolon (;) and the Notes or Domino directory path. For example:

```
%systemroot%\system32\%systemroot%;C:\Notes
```
- 5 Save the changes and close the dialog box.
- 6 For the changes to take affect, shut down and restart the computer.
- 7 Confirm the path is set correctly by repeating steps 1 through 3 above.

To set up the computer's system path for Windows 2000

- 1 From the Start menu on the Unified Messaging Trial Software computer, select Settings>Control Panel and then double-click "System."
- 2 Click "Advanced" and then click "Environment variables."
- 3 In the System Variables box, locate and select the path and then click "Edit."
- 4 At the end of the current path, type a semicolon (;) and the Notes or Domino directory path. For example:

```
%systemroot%\system32\%systemroot%;C:\Notes
```
- 5 Click "OK" and close the dialog box.
- 6 Confirm the path is set correctly by repeating the "To confirm the system path exists" procedure above.

Installing voice boards

Unified Messaging Trial Software requires a voice board, which is a phone interface card, to physically connect phone lines or extensions from the phone system (or the phone company's system) to the Unified Messaging Trial Software system.

Before installing Unified Messaging Trial Software, install and set up the voice boards. All Dialogic voice boards are shipped with installation and setup instructions.

The following Dialogic voice boards are supported by PhoneSoft Unified Messaging Trial Software.

Board	Bus
ProLine/2V	ISA
Dialogic D/41EPCI	PCI
Dialogic D/41ESC	ISA
Dialogic D/41H	ISA
Dialogic D/120JCT-LS	PCI
Dialogic D/160SC-LS	ISA
Dialogic D/240PCI-T1	PCI

To find and reserve memory addresses and an IRQ address (for ISA boards only)

- 1 On the Dialogic System Software disc, run the Dialogic Configuration Manager utility to reserve resources for a legacy ISA board, including:

- 32 KB of memory in the D0000 range (D0000 to DFFFF).
- IRQ 5.

If IRQ 5 is already in use by a PCI board (a network interface card, for example), you can force the system to reserve IRQ 5, which will cause the PCI board to use another IRQ. If IRQ 5 is not available, try IRQ 7 or 2.

- 2 Write down the memory addresses that you reserved. You will need to specify these values when setting up the voice board.

Continued

Installing a voice board

- 1 Attach an antistatic wrist strap.
- 2 If you already turned on the computer, shut down the software and then shut down the computer.
- 3 Remove the cover from the computer or expansion chassis.
- 4 Select an empty ISA or PCI slot as appropriate, and remove the slot's retaining screw and access cover plate.

NOTES: PCI boards can be put into either 32-bit or 64-bit PCI slots.

All ISA boards and all boards with SC or CT bus connectors must be installed in the same box. If not all boards fit in the Unified Messaging Trial Software computer, then you must install all of them in an expansion chassis.

- 5 Perform the applicable procedures to set the switches and jumpers on each board. See “Appendix” on page 21.
Some boards include hardware settings that indicate which board is first, which is second, and so on. If you are installing more than one board of the same model, keep the boards in order so you can install them in the correct order in the next step.
- 6 Insert each board firmly into its slot, and fasten each board to the computer's backplate with a screw.
If you are installing more than one board of the same model, and if the boards include a hardware setting that indicates which board is first, second, and so on, install the boards in the order specified by the hardware settings.
- 7 If you are installing multiple voice boards that have SC or CT bus connectors, cable the boards together. On each board, connect the cable so the red stripe on the cable corresponds with pin 1 on the board connector. Confirm that the connectors are firmly seated.
If the cable has more connectors than the computer has voice boards, use the first and last connectors, and leave unused connectors in the middle of the cable. If the end of a cable is allowed to dangle loose, it can act as a radio antenna and pick up noise from the bus.
If you are cabling three or more boards together, connect the first connector on the cable to the first board, the second connector to the second board, and so on.
- 8 Replace the cover of the computer or expansion chassis.

Setting up the voice boards

After installing one of the supported Dialogic voice boards, install the driver software.

If you purchased the voice boards from Active Voice, your voice board package includes a Dialogic System Software disc.

The following procedures are provided as examples of a typical installation and setup. The Dialogic installation program provided for your voice boards may be slightly different. For detailed instructions, refer to the voice boards' documentation.

To set up the voice boards, perform the following procedures.

To test that a board was installed and set up correctly, perform "To test a board's setup" on page 14.

To install the Dialogic software

- 1** Insert the Dialogic System Software disc in the Unified Messaging Trial Software computer's CD-ROM drive.
- 2** Go to the disc's directory and double-click the Setup.exe file.
- 3** Follow the on-screen instructions and select the Typical Installation option.

To set up the boards

- 1** From the Windows Start menu, select Programs> Dialogic System Software>Configuration Manager.
- 2** Click the Add Board to Configuration menu.
- 3** Click the board that you are installing.
- 4** Follow the on-screen instructions to set up the board.
- 5** After completing the setup, repeat steps 1 through 4 for each board.
- 6** After setting up all of the boards, click "End Configuration," save your settings and exit the utility.

Continued

To set up the board to automatically start with the computer

- 1** From the Start menu, choose Programs>Dialogic System Software.
- 2** Click “Service” and then click “Start Up Mode.”
- 3** Click “Automatic.”
- 4** For Windows NT systems, perform the next procedure.
For Windows 2000 systems, perform “To install the WAV driver files for Windows 2000” on page 14.

To install the WAV driver files for Windows NT

- 1** From the Start menu, choose Settings>Control Panel.
- 2** Double-click “Multimedia.”
- 3** In the Properties box, choose the Devices tab and then click “Add.”
- 4** Click “Unlisted or updated driver” and then click “OK.”
- 5** In the Install Driver dialog box, click “Browse.”
- 6** Go to the directory that contains the Dialogic drivers and choose the Lib subdirectory. The default directory is C:\Program files\Dialogic\Lib.
- 7** Click “OK” twice.
- 8** When the “Add uninstalled or updated driver” dialog box appears, confirm that “Dialogic WAV Driver 1.x” is displayed and then click “OK.”
- 9** If a message appears indicating that the file already exists, click “New.”
- 10** From the Dialogic Wave Driver Configuration box, choose “OK” to accept the default settings.
- 11** Restart the computer to update the system.

To install the WAV driver files for Windows 2000

- 1** From the Start menu, choose Settings> Control Panel.
- 2** Double-click “Add/Remove Hardware.”
- 3** From the Add/Remove Hardware Wizard dialog box, click “Next.”
- 4** Select “Add/Troubleshoot a device” and then click “Next.”
- 5** Select “Add a new device,” then click “Next.”
- 6** Select “No, I want to select the hardware from a list” and click “Next.”
- 7** Select “Sound, video and game controllers” and click “Next.”
- 8** When asked to select a device driver, select “Standard system devices” and then click “Have Disk.”
- 9** Go to the directory that contains the Dialogic software and then go to the Lib subdirectory.
- 10** Open the Oemsetup.inf file and click “OK.”
- 11** Confirm that “Dialogic Wave Driver 1.x” is selected and then click “Next.”
- 12** Select “Hardware Installation” and click “Next.”
- 13** When the Digital Signature dialog box appears, click “Yes.”
- 14** If the Files Needed dialog box appears, confirm that the path is set correctly and click “OK.”
- 15** At the Dialogic Wave Driver Configuration dialog box, click “OK” and then click “Finish.”
- 16** Restart the computer to update the system.

To test a board’s setup

- 1** From the Windows Start menu, select Programs> Dialogic System Software>Universal Dialogic Diagnostic Utility.
- 2** Click the board that you want to test.
- 3** Click “Run Tests.” It may take several minutes for these to run.
If any errors are reported, resolve them before continuing with the Unified Messaging Trial Software installation process.

Setting up the phone system

How the integration works

Phone lines connect the phone system and the Unified Messaging Trial Software computer. Unified Messaging Trial Software supports many types of analog, DID (Direct Inward Dial), and digital (T1, E1) phone lines. The voice board installed in the Unified Messaging Trial Software computer must match the lines from the phone system or the phone company's central office.

The following illustration shows a typical Unified Messaging Trial Software and phone system integration.

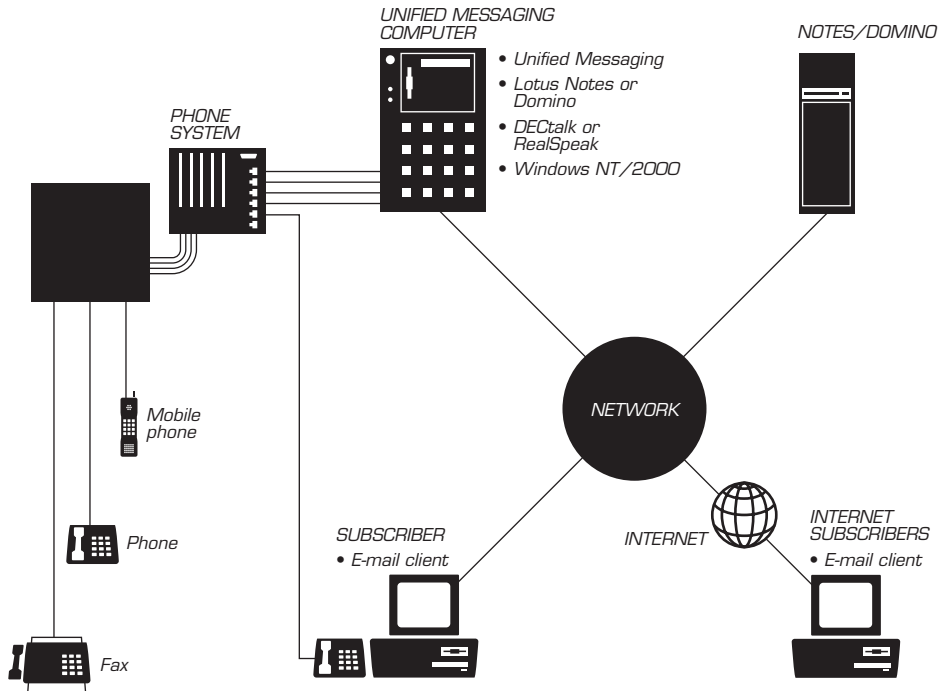

With a typical integration, the phone system may send the following information with forwarded calls:

- The called party's extension
- The reason for the forward (the extension is busy, does not answer, or is set to forward all calls)
- The calling party's extension (for internal calls)

Unified Messaging Trial Software uses this information to answer the call appropriately. For example, a call forwarded to Unified Messaging Trial Software is answered with the user's personal greeting. If the phone system routes the call to Unified Messaging Trial Software without this information, Unified Messaging Trial Software answers with the opening greeting.

Unified Messaging Trial Software offers one or more of the following that may take advantage of features found on your phone system.

Call forward to personal greeting When an incoming call is routed to an unanswered or busy extension, the call is forwarded to the user's voice mail. The caller then hears the user's personal greeting and can leave a message. To set up this feature, you need to use the PhoneSoft SDK Script Generator and a Lotus agent.

Easy message access If the phone system uses a serial integration (SMDI or MCI), a user can retrieve messages without entering an ID. Unified Messaging Trial Software identifies a user based on the extension from which the call originated. A password may be required. To set up this feature, you need to use the PhoneSoft SDK Script Generator and a Lotus agent.

Message waiting indication (MWI) When a message is waiting for a user, Unified Messaging Trial Software notifies the phone system to activate the message waiting indicator on the user's extension.

Setting up the phone system

The following procedure provides general information about setting up a phone system; refer to your phone system documentation for specific information.

To set up the phone system

- 1 Assign extensions for the voice mail ports, which are the lines connecting the phone system and Unified Messaging Trial Software.
- 2 If the phone system supports hunt groups, set up the hunting order for the voice mail extensions (port 1 to port 2, and so on).
If the phone system does not support hunt groups, you can simulate a hunt group by forwarding each voice mail extension to the next extension in the simulated hunt group on busy.

Continued

- 3 If the phone system supports hunt group access codes, assign a hunt group access code for the voice mail extensions. This code is the number that users dial internally to connect to Unified Messaging Trial Software.
- 4 Program which trunks (if any) will route to the voice mail extensions.

- 5 Program the phone system to handle calls when all voice mail ports are busy. Calls may be forwarded to an operator, get a busy signal, or get a ringback tone until one of the ports becomes available.

Testing the setup

To test that the phone system is set up correctly, perform the following procedure.

To test the phone system setup

- 1 Locate a standard analog phone set with a ringer. If the system uses feature phone sets, use a feature set for the test.
- 2 If the voice boards use RJ-14 connectors, locate a line splitter to separate the two extensions carried by each phone line.
- 3 Connect the test phone set to the phone system by using a line designated as a voice mail extension.
- 4 Confirm that the phone system identifies DTMF (dual tone multiple frequency) tones to the test extension.
Do this by dialing a station phone from the test phone. Have someone answer the station phone and dial a number. You should hear the tone on the test phone. Repeat this test for each type of station connected to the phone system (for example, analog or operator).
- 5 Confirm that the test phone can access outside lines.
To do this, dial a number outside of the phone system from the test phone. You should reach the outside number.
- 6 Confirm that the phone system generates rings on the test extension.
To do this, use a station phone to dial the test phone's extension. The test phone should ring.
- 7 For phone systems that support trunk routing, check that trunk routing is set up correctly for extensions that only answer calls from stations.
To do this, dial the test phone's extension from a station phone. Answer the test phone and perform a hookflash (timed break recall); then dial a station phone, listen for ringing, and disconnect. The call should be transferred to the phone that you dialed.

Connecting Unified Messaging Trial Software and the phone system

After setting up and testing each of the voice mail phone lines on the phone system, you need to connect the two systems.

The type of phone line that you use to connect the two systems, depends on the type of voice boards installed in the Unified Messaging Trial Software computer. Refer to “Appendix” on page 21 for information about a supported voice board’s connectors and port size.

To connect the phone system to Unified Messaging Trial Software

- Connect a phone line from each phone system extension to a socket on the voice board backplate of the Unified Messaging Trial Software computer.

Installing and starting Unified Messaging Trial Software

Installing Unified Messaging Trial Software

After setting up the voice boards and the phone system integration, perform the following to install Unified Messaging Trial Software.

After installation, you can set up Unified Messaging Trial Software to automatically start when the computer starts. To do this, set up Unified Messaging Trial Software as an NT Service by performing the second procedure.

To install Unified Messaging Trial Software

- 1 Locate and open the Unified Messaging Trial Software Setup_umc.exe installation file.
- 2 Click “Yes” when asked if you want to install the software.
- 3 When asked, type the password that you received with the license file and then click “OK.”

NOTE: The password is case sensitive.

- 4 Follow the on-screen instructions to complete the installation.
- 5 Copy the Umailcall.lic file into the directory that contains the Phoneserver.exe file.

If you received the Umailcall.zip file in an e-mail message, copy the file to a temporary directory, unzip it and then copy the Umailcall.lic file to the same directory as the Phoneserver.exe file.

To set up Unified Messaging Trial Software as an NT Service

- 1 From the Start menu, choose the Run menu.
- 2 Type phoneserver_-i and click “OK.”
- 3 Start Phone Server.
- 4 In the Phone Line Status Grid box, double-click each phone line and click “Autostart.”

Starting Unified Messaging Trial Software's Phone Server

Phone Server provides a system administrator interface for setting up and maintaining Unified Messaging Trial Software and the phone system integration.

You can use Phone Server to monitor system status and examine system utilization.

To start Phone Server

- From the Start menu, choose the Programs>PhoneSoft>Phone Server menus.

To close Phone Server

- Click the File>Exit menus.

Changing default settings

Before Unified Messaging Trial Software can answer calls, you need to set up the system.

The standard installation sets up the system with the common defaults for automated attendant and other system options. To modify the standard setup, perform the procedures below.

To change phone line settings

- 1 Start Phone Server.
- 2 Go to the Phone Line Status Grid and double-click the phone line for which you want to change the settings.

To change Unified Messaging Trial Software default settings

- 1 From the Phone Server menu bar, select the Edit>Configuration menus.
- 2 In the Phone Server Properties dialog box, you can change the settings available in these windows. Refer to the Phone Server Help File for setting descriptions.

Automated attendant options

After the corporation's opening greeting, callers are offered a menu of options. The system administrator can redefine these options. By default, the following options are provided:

Extension number The system will transfer a call when a caller enters a user's extension at any time during the greeting.

0 (Operator) Callers can dial 0 to call the operator during most menu conversations. Any extension or phone number can be set up as the operator.

***NOTE:** Callers with rotary phones or callers who do not dial a menu selection are also transferred to the operator.*

1 (Spell-by-name directory assistance) This option transfers calls to the directory for spelling a user's name. Directory assistance can be set up to present names beginning with either first or last name. Up to ten letters may be entered. The order of the name is determined by the NAB database "Name" field.

Call transfer

Depending on the phone system, call transfers can be set up in a variety of different ways. The phone system transfer settings are set up in the Phone Server Edit>Configuration>Transfer Settings menu.

By default, when a call is answered by a user, the call is released. When a call is unanswered or busy, these are the default menu choices a caller hears:

1 Leave a voice message

2 Transfer to another extension

3 Page the user Available for a user that is set up with an enabled pager.

4 Hold until the extension is available The system waits for a set time, and then tries the extension again.

0 for the operator

Modifying menu and prompt settings

All system menu choices and prompt settings can be modified. You can minimize user training by customizing menus and prompts to match up with what users are used to using.

The custom prompts directory can contain custom or site specific prompts for your application. When a prompt is stored in this directory it takes precedence over the file of the same name in the Prompts directory. Files in this directory are not removed during a PhoneSoft reinstall, upgrade or uninstall.

To modify a Unified Messaging menu

- 1 In Phone Server, click the Edit>Mailcall>Menus menus.
- 2 Make changes as appropriate.
- 3 After modifying a menu setting, click “Apply” and then click “OK.”

To modify a prompt

- 1 After recording your custom prompts, rename the files to match the files that you are replacing.
- 2 Then copy the customized prompt into the C:\PhoneSoft\MailCall\CustomPrompts directory.

Message waiting indication

Depending on how the phone system is set up, Unified Messaging Trial Software can send signals to turn the user’s MWI (message waiting indicator) on or off, as appropriate.

Unified Messaging Trial Software has two options for setting up message waiting indication. You can set up the system to set MWI on when a new message appears in:

- Any of the user's mailbox folders or views.
- The user's inbox folder. This option is faster and more appropriate for sites with 500 or more users.

Unified Messaging Trial Software supports SMDI (simple message desk interface) signaling. SMDI signaling is a serial connection between the phone system and Unified Messaging Trial Software. If the phone system supports an SMDI link, please contact your sales representative for more information. The Unified Messaging Trial Software SMDI interface is sold separately.

To set up SMDI signaling

- 1** Locate and copy the Smdi.lic file to the directory that contains the Phoneserver.exe file. The default is C:\PhoneSoft.
- 2** Start Phone Server.
- 3** Click the Edit>SMDI Link menus.
- 4** In the SMDI Link dialog box, select the "SMDI Link Enabled" check box.
- 5** Select the appropriate "Com port," and "PBX type," and then click "OK."
- 6** When the message appears, click "OK."
- 7** In Phone Server, click the Edit>Configuration menus and select the MWI Settings tab.
- 8** Select the Enable MWI check box and type the appropriate time in the "Update Period" field.
- 9** Then click "Use SMDI Link."
- 10** In the Unread Handling section, click "Match Inbox (Single Folder)" and click "OK."
- 11** Close and restart Phone Server.

DID environments

If the corporation uses DID (Direct Inward Dial) extensions, callers can automatically forward busy or unanswered calls directly to the user's mailbox.

Changing message sort order

Unified Messaging Trial Software supports customizing a Notes view for sorting and viewing messages in various ways. The system is limited to one configured view for each user.

Call Pursuit

Unified Messaging Trial Software can intelligently attempt to find a user and transfer a call to a forwarding number. Users can set up their mailboxes with multiple forwarding numbers, and the system will sequentially try each of these numbers. You can make this option available (or unavailable) to users through Notes.

For Call Pursuit of external phone numbers, the phone system must be set up for three-way conference calls with external phone numbers.

Setting up users

Unified Messaging Trial Software stores user settings in a Domino directory or Notes NAB (Name and Address Book).

Unified Messaging Trial Software can use either your company's existing NAB or a separate NAB. System administration is simpler when using the company NAB. For example, when adding user names and settings, the users will automatically be set up to use Unified Messaging Trial Software as well.

A sample database is included with Unified Messaging Trial Software. This NAB contains the additional forms, views, and fields required by Unified Messaging Trial Software.

To set up users in the company NAB, copy these views and fields into that NAB by performing the procedure below. To set up users in the sample NAB, perform the procedure that starts on page 27.

After performing one of the following two procedures, you need to set up users to access their mail files over the phone. See “To set up Unified Messaging Trial Software to access a company’s NAB” on page 30. For further assistance, contact your company’s Notes or Domino administrator.

To set up users in the company NAB

- 1** On the Unified Messaging Trial Software computer, log in to Notes or Domino.
- 2** If using the company NAB, continue to step 3.
If using a replica of the company NAB, locate and create a replica of the company’s NAB (default is Names.nsf), from the Domino server to the Unified Messaging Trial Software client, into the \Lotus\Notes\Data directory.
- 3** Click the Domino Designer icon.
- 4** Locate and open the Unified Messaging Trial Software PS Names mail database (Psnames.nsf) in the \Phonesoft directory.
- 5** Locate and open the company NAB on the server or the replica NAB in the \Lotus\Notes\Data directory.
- 6** In the PS Names mail database, click “Forms” and then open the Person form for editing.
- 7** Highlight and copy all of the PhoneSoft fields.
- 8** Go to the company’s NAB or replica NAB, click “Forms,” and then open the Person form for editing.

9 If using Notes or Domino version 4.6 or earlier, do the following:

- Locate the Misc section, click once below the Misc section to get the cursor in that area and then click the Edit>Paste menus.
- Confirm that all of the PhoneSoft fields appear in the Person form list between the Misc and Public Keys sections.

If using version 5.0 or higher, click on a Person tab that you want to add the PhoneSoft tab after and do the following:

- Right-click and click the Insert Row menu.
- Select the new tab, right-click and click the Table Properties Menu. In the Table Row tab, type PhoneSoft in the “Tab Label” box and close the Table dialog box.
- Select the PhoneSoft tab, right-click and click the Paste menu to copy in the PhoneSoft fields.

10 Close and save the updated Person form.

11 In the PS Names mail database, click “Views” and then open the Person view for editing.

12 Highlight and copy all of the PhoneSoft fields.

13 Go to the company’s NAB or replica NAB, click “Views,” and then open the Person view for editing.

14 If using Notes or Domino version 4.6 or earlier, do the following:

- Locate the Misc section, click once below the Misc section to get the cursor in that area and then click the Edit>Paste menus.
- Confirm that all of the PhoneSoft fields appear in the Person form list between the Misc and Public Keys sections.

If using version 5.0 or later, click on a view tab that you want to add the PhoneSoft tab after and do the following:

- Right-click and click the Insert Row menu.
- Select the new tab, right-click and click the Table Properties Menu. In the Table Row tab, type PhoneSoft in the “Tab Label” box and close the Table dialog box.
- Select the PhoneSoft tab, right-click and click the Paste menu to copy in the PhoneSoft fields.

Continued

15 If using the company’s NAB, skip to step 19.

If using a replica NAB, click the File>Database>Properties menus.

- 16 Confirm that the window has the Replica NAB title and then click the Design tab.
- 17 To save the field additions to the Replica NAB only, clear the “Inherit design from template” check box.
- 18 Save and close the Database Properties window.
NOTE: If you want everyone using the template database to have these buttons, repeat this procedure for the template database.
- 19 Close and save the updated Person view and exit Domino Designer.
- 20 For each user, type the appropriate information for each PhoneSoft field. For field descriptions, see step 4 in the next procedure below.

To set up users in the sample NAB

- 1 Locate and copy the Psnames.nsf file from C:\PhoneSoft to the Lotus\Notes\Data directory on the Unified Messaging Trial Software computer.
- 2 Start Domino Designer and open the Psnames.nsf file, which is the sample NAB.
- 3 Click the Create>Person menus to add each user into the sample NAB.
- 4 The information required for each user allowed to call in or receive mail from Unified Messaging Trial Software is contained in the Person Documents in the NAB. Set up the following fields for each user.

Canonical name Stores the user’s full Notes canonical name and uses it for unread messages. For example, CN=Sandy Green/O=Active Voice.

Spelled last name Stores the user’s last name. Automatically computes the keypad number of last names. For example, Green is saved as 47336.

Mail address Stores the user's Notes mail address.

Mail server Stores the mail server’s name containing the user's mail file. Unified Messaging Trial Software supports user mail files residing on different mail servers.

Mail file Stores the user’s mail file name and directory path. This name and path must match the user’s corresponding mail file name and path in the mail server's database. For example, Mail\sgreen.nsf.

Mailbox number Stores user’s mailbox number, extension, employee number or any other number that is unique to this user. A user enters this number to access his or her mailbox.

Mailbox password Stores the user's password. You can set this for the user and then have the user change it later. This field is protected using Notes one-way encryption.

Name recording Stores the user's name recording as a Wav file.

Greeting Stores the user's greeting as a Wav file. For example, "I'm unavailable to take your call. Please leave me a message."

Absence greeting Stores the greeting played when this greeting is enabled and the user is unavailable to answer the call. For example, "I'm out of the office, but will check messages in the morning." When this greeting is active, the "Log missed calls" field is ignored and no call screening message recordings are sent for these missed calls.

***NOTE:** The "Do not disturb" setting that is available with some phone systems, is not recognized by Phone Server. However, the user can use the Absence greeting as a "Do not disturb" setting for Phone Server.*

Phone extension Three fields for storing three user phone system extensions or external phone numbers that Unified Messaging Trial Software can use to contact the user. The first field value is usually the same as the "Mailbox Number" field.

When more than one "Phone extension" field is used, Unified Messaging Trial Software calls each extension, one at a time, to contact the user, which is also known as Call Pursuit.

You can use the three field settings to resolve situations when different extensions are required. For example, when a user wants to receive calls on a cellular phone, the user can set up one of these fields to forward all calls to the cellular phone number.

Enable or disable extension Enables or disables the use of the corresponding "Phone extension" field.

Type Sets the type of call transfer to the corresponding “Phone extension” field. Settings include default, blind or supervised. The most common settings are supervised for external numbers and default for internal extensions.

With the default setting, the system uses whatever the phone system is set up to do. However, Unified Messaging Trial Software can override the phone setting with either the blind or supervised setting.

With a blind transfer, the extension is dialed and then the call is released immediately. Because the call is released, the other two phone extensions are not used.

With a supervised transfer, the call is monitored by the system and is released if the call is answered. If the called extension is busy or unanswered, then the system tries any other set phone extensions and then handles the call based on what is set up for that user. For further details, see “How the integration works” on page 15 and “Call transfer” on page 21.

Pager address Stores the user’s e-mail address for the user’s pager. See the Notes Pager Gateway Administrator's Guide for details.

Numeric page string The dial string needed to send the numeric page.

Enable or disable pager Enables or disables the use of the “Pager address” field.

Call screening enabled Enables or disables call screening for a user’s extension.

Confirm deletions Set for users that want a confirmation message before deleting a message from their mailbox.

Log missed calls Set for users that have Call screening enabled and want to receive just the call screening recording from a caller that leaves no message or if the call transfer failed.

When a user’s Absence greeting is active, this field is ignored and no call screening message recordings are sent for these missed calls.

Conversation monitoring Enables the use of conversation recording or monitoring.

Machine name Store's the user’s computer name for the Popup feature.

MWI state Used by the system to display MWI status; cannot be changed.

View selection Sets the view used for reviewing messages by phone.

- 5 Confirm that all of the PhoneSoft fields appear in the Person form list between the Misc and Public Keys sections.
- 6 Close and save this form.

To set up Unified Messaging Trial Software to access a company's NAB

- 1 Start Phone Server and click the Edit>Configuration menus.
- 2 In the Phone Server Properties dialog box, click the "Names server" field.
- 3 Do one of the following:
 - If using a company's NAB on the Domino server, type the NAB file name. Local files must be stored in the \Lotus\Notes\Data directory.
 - If the NAB database is located on the Unified Messaging Trial Software computer, leave this field blank.
- 4 Click "OK" to save the settings.

To create a Phoneserver Notes ID for the Unified Messaging Trial Software computer

- 1 Open Domino Administrator and go to the People section of the company's mail database.
- 2 Click the People section and then click the Tools list.
- 3 From the Tools list, click the People list and then click "Register."
- 4 In the New Entry dialog box, click the Registration Server button.
- 5 From the Registration Server list, locate and select the Domino domain name of the company's mail database and click "OK."
- 6 In the "Last Name" field, type phoneserver.
- 7 In the "Password" field, type a password.
- 8 Select the "Advanced" check box and then click the ID Info icon.
- 9 Select the "In File" checkbox and then click "Set ID File."

Continued

- 10 In the "File name" box, type a name, click "Save" and close the dialog box.
- 11 Click "Add person" and then click "Register" to create the ID.

***NOTE:** Notes security is best maintained by using a separate ID, because only the system administrator has access to this special Notes ID, and no user has any access to any other user's mail file.*

To add the Phoneserver ID to the Access Control List for each user mail file

- 1** Open a user's mail file in Notes or Domino.
- 2** Click the File>Database>Access Control menus.
- 3** In the Access Control List dialog box, click "Add."
- 4** Click the Person icon and then browse the Domino server to locate the Phoneserver person ID (that you just created in the previous procedure).
- 5** Select the Phoneserver person, click "Add" and then click "OK."
- 6** In the Access Control List dialog box, select the Phoneserver person and then from the Access list, click "Manager." Manager access is required for accurate unread message information.
- 7** To allow a user to delete mailbox messages over the phone, select the "Delete documents" check box in the Access Control List dialog box.
- 8** Repeat this procedure for each user mail file.

Setting up phone lines

You may want to change the system default settings for the phone lines. To change the settings, perform the following procedure.

After changing the settings for a phone line, you can test the setup by calling in to the phone number or extension shown for that line.

To set up a phone line

- 1 In the Telephone Line Status Grid, double-click the line that you want to set up.

NOTE: If the fields are grayed out, then an application may be active on that line. To stop activity, click “Stop” and then click “Yes.”

- 2 In the Line Setup dialog box, go to the “Phone #” field and type the extension number that the phone system will use to access this line.
- 3 In the Application list, select “Unified MailCall” and click “Start” to start the application.
- 4 If you want Phone Server to automatically run the selected application on this line, select the “Auto Start” check box.
- 5 Click “Close” to complete the setup.
- 6 Repeat this procedure for each phone line.

NOTE: When a phone line is set up correctly, the Status Grid displays the application as up and running and the Activity displays “Waiting for Call.”

Installing RealSpeak

RealSpeak™ is an optional TTS package that provides a more natural sounding voice.

US English is the TTS language included and installed with RealSpeak.

To install this package, perform the procedure below.

To install RealSpeak

- 1** Confirm that the system is using version 5.1A or higher of PhoneSoft software. If not, contact your sales representative to upgrade.
- 2** Locate and double-click the Realspeak_tts_us_v2b.exe file on the PhoneSoft disc.
- 3** When asked, type your password and click “OK.” The password is located in the Readme file on your license diskette.
- 4** When asked, type the Unified Messaging Trial Software directory path that contains the Umailcall.exe file. The default is C:\PhoneSoft\Mailcall.
- 5** Follow the on-screen instructions to complete the installation.
- 6** After clicking “Finish,” start Phone Server.
- 7** Click the Edit>Configuration menu and then click the TTS tab.
- 8** In the Interface box, click “RealSpeak.”
- 9** In the Key box, type the license key code and click “Upgrade.” The code is located in the Readme file on your license diskette.
- 10** Confirm the appropriate number of TTS licenses are displayed above the Key box. If the wrong number appears, confirm that you typed the code correctly.
- 11** Close the Configuration box and restart Phone Server.

Installing additional languages

When using DECTalk™ Text To Speech (TTS), Unified Messaging Trial Software automatically installs the US English language for you. When using RealSpeak, you need to install the language when you install RealSpeak.

In order to use other available languages or additional languages with Unified Messaging Trial Software, you will need to install them after installing Unified Messaging Trial Software.

The following are examples of other available languages that are included on the PhoneSoft disc for DECTalk.

- German (Dectalk_gr_tts.exe)
- Latin American Spanish (Dectalk_la_tts.exe)
- Castilian Spanish (Dectalk_sp_tts.exe)
- United Kingdom / British English (Dectalk_uk_tts.exe)

At the time this was published, English was the only language available with RealSpeak.

After receiving one or more language files, perform the following two procedures to install and set up TTS languages.

After setting up the system for multiple languages, as described on page 35, callers can press 2 to change to a different TTS language. The menu options will be presented in the order listed in the Mailcall.ini file. The "Language_x" lines define the language to be selected by pressing the corresponding menu numbers. The "Description_x" lines define the corresponding menu option played for each menu number.

To install a TTS language

- 1 Locate the language file on the PhoneSoft disc.
- 2 Copy the language file to a temporary directory on the Unified Messaging Trial Software computer.
- 3 Locate and write down the language's password that is listed in the Readme file on the license diskette.
- 4 Double-click the language file.
- 5 When asked, type the appropriate password as found in step 3.
- 6 When asked, type the Unified Messaging Trial Software directory path that contains the Umailcall.exe file. The default is C:\PhoneSoft\Mailcall.
- 7 Repeat this procedure for each language that you want to install.

Continued

To set up Unified Messaging Trial Software for multiple TTS languages

- 1 Use a text editor to open the Mailcall.ini file.
- 2 Locate the TTS Languages section in the file.
- 3 Specify the default and the order in which the other languages are offered. For example, type the following for US English as the default and the other language options in the order listed.

[TTS Languages]

Language_1=ENGLISH, US

Description_1=American English

Language_2=ENGLISH, UK

Description_2=The Queen's English

Language_3=SPANISH

Description_3=Spanish

Language_4=LATIN AMERICAN

Description_4=Latin American Spanish

Language_5=GERMAN

Description_5=Deutsch

- 4 Save and close the file.

Setting up Play By Phone and Play Multimedia

PS Desktop is an optional TTS (text to speech) client application for Phone-Soft. With PS Desktop, users can click either the Play By Phone or Play Multimedia button and listen to inbox messages over their phones.

Perform the following three procedures to install and set up PS Desktop and the buttons in the Notes or Domino NAB database. The PS Desktop buttons will then be available from that NAB database's Memo Form.

Use the second procedure to install the PS Desktop buttons in any Notes inbox folder, view or form. PS Desktop uses a Unified Messaging Trial Software port while a message is playing.

***NOTE:** If using a replica database and you want everyone using the Notes template database to also use the PS Desktop buttons, repeat the last two procedures for the template database.*

To install PS Desktop

- 1** Confirm that TCP/IP is set up on the client and the Unified Messaging Trial Software computers.
- 2** Confirm that the IP network is installed correctly. You can use Chatter and Chatsvr, which are two Microsoft programs included with PS Desktop.
- 3** Locate and double-click the Ps_desktop.exe file.
- 4** In the Attachment Properties dialog box, click "Launch." The self-extracting file installs the software.
- 5** From the Start menu, click Programs>Phonsoft>PS_Desktop to start the utility.
- 6** Select Edit>Phone Number and type the user's phone extension.
- 7** Select Edit >Phone Server Name and type the IP address of the computer running the voice mail system (or if your IP addresses are dynamic, type the Windows Network Name).
- 8** Close the program.

Continued

To add “Play by phone” and “Play multimedia” to a user’s memo form

- 1 Start Domino Designer by clicking the Start>Programs>Lotus Application>Lotus Domino Designer menus.
- 2 From Domino Designer, click the File>Database>Open menus and type the directory path and name to open the Psmail.nsf file.
- 3 Do the same to open the NAB database for which you want to add the PS Desktop buttons.
- 4 Under Recent databases, locate “PS Sample Mail Database R5.”
- 5 To open the Psmail.nsf memo form, click “Forms” and then double-click “Memo.”
- 6 Confirm the Action Pane window is visible in the Domino Designer window. If not, click View/Action and select the “Action pane” check box.
- 7 In the Psmail.nsf memo form, click the “Play multimedia” action once and then click the Edit>Copy menus.
- 8 Under Recent databases, locate the Notes NAB database for which you want to add the PS Desktop buttons.
- 9 To open the NAB database memo form, click “Forms” and then double-click “Memo.”
- 10 If the NAB database is a template, skip to step 14.
If the NAB database is not a template, a message appears about losing any changes made to the form because the master copy is in a different design template database. Go to the next step.
- 11 Click the File>Database>Properties menus and click the Design tab.
- 12 To save the additions of these buttons to this database only, clear the “Inherit design from template” check box.
- 13 Save and close the Properties window.
- 14 From the Domino Designer, confirm the Action Pane window is visible in the NAB database.
- 15 Paste the “Play multimedia” action from the Psmail.nsf file to the NAB database.

- 16** In the Action Pane window, click the first action and then click the Edit>Paste menus to copy “Play multimedia.”
- 17** In the Action Pane window of the Psmail.nsf file, select the “Play by phone” action and then click the Edit>Copy menus.
- 18** In the Action Pane window of the NAB database, click the first action and then click the Edit>Paste menus to copy “Play by phone.”
- 19** Save and close the NAB database memo form.
- 20** Repeat this procedure for all users that you want to use “Play by phone” and “Play multimedia.”

To add the Play By Phone and Play Multimedia agents to the NAB database

- 1** From Domino Designer, click the File>Database>Open menus and type the directory path and name to open the Psmail.nsf file.
- 2** Do the same to open the NAB database for which you want to add the macros.
- 3** Under Recent databases, locate “PS Sample Mail Database R5.”
- 4** To open the Psmail.nsf agents, click “Agents” and then click “PS Multimedia Playback.”
- 5** Press and hold CTRL and click “PS telephone playback.”
- 6** Click the Edit>Copy menus to copy both agents.
- 7** Under Recent databases, locate the Notes NAB database for which you want to add the PS Desktop agents.
- 8** To open the NAB database agents, click “Agents” and then click anywhere in the Agents Pane window to make it the active window.
- 9** Click the Edit>Paste menus to paste the agents.
- 10** Confirm the agents are listed and then close and save the NAB database Agents Pane window.

Troubleshooting read and unread messages

Lotus Notes read and unread message problems can be caused by copies of the unread message lists not matching up or conflicting.

A copy of the unread message list for each user is stored by Lotus Notes in three places:

- Notes mailbox database
- User's Desktop.dsk file
- Notes client as an unread journal log in the Cache.dsk file

When PhoneSoft queries a mailbox database for unread messages, Notes returns the list of unread documents from the database. PhoneSoft then arranges and presents the unread messages to the user. The number of unread messages when calling from the phone should be the same as the number of unread messages viewed in the mailbox from the Notes client or browser on any computer.

Canonical name problem

Lotus Notes uses the User's Canonical Name to track unread messages. The “Canonical Name” field is located in the PhoneSoft section of the Domino NAB.

If this field is incorrectly set up in the NAB, the user receives a different number of unread messages from the phone, as compared to the Notes desktop.

To find the “Canonical Name” field value

- 1 Open the users mail file.
- 2 Find a document created by that user, highlight and right-click the document.
- 3 Select the Document Properties menu.
- 4 Click the Fields tab.
- 5 In the “From” field list, locate the correct Canonical Name as shown on the bottom right of the window (example: CN=Sandy Green/O=Your Company).
- 6 Highlight, copy, and paste this Canonical Name into the Unified Messaging Trial Software NAB “Canonical name” field. (Do not copy the quotes.)

Mail file open conflict

When user mail files are open on their desktops and they check messages over the phone, the read and unread message information can be inaccurate. The inaccuracy is caused by Notes updating the database copy of the unread list only when user mail files are closed on the desktop. This situation is resolved by Notes when users close their mail files.

Access Control List problem

Notes requires that the Notes ID for the Unified Messaging Trial Software computer have the Manager access level to user mail files. Without Manager access, users are unable to receive read and unread message information and a corresponding error appears in the Phone Server log when users try to check unread messages. See “To create a Phoneserver Notes ID for the Unified Messaging Trial Software computer” on page 30.

View problems

By default, Unified Messaging Trial Software searches for and reads messages from the Notes (\$Inbox) folder. To create a custom view, you can create a view named \$PS Review. When the \$PSReview view exists in user mailboxes, Unified Messaging Trial Software automatically uses that view instead of the \$Inbox view for reviewing all phone based messages.

For Unified Messaging Trial Software to successfully use the \$PS Review view, specific column positions are mandatory. See the sample database, the Psmail.nsf file, for column positions.

When Unified Messaging Trial Software uses a specific view (\$Inbox or \$PS Review) for message review, only unread messages in that view are seen by Unified Messaging Trial Software.

Replica database problems

When using replica database files with Unified Messaging Trial Software and Notes, users can get confused by inaccurate read and unread message information. Unread message information does not replicate between database replicas, however it is not always immediate. So when users check unread messages both by phone and desktop close to the same time, the message counts can be inaccurate, because replication has not yet occurred.

Continued

Notes servers earlier than version 4.5

With this older software, an error message appears in the Phone Server log that an unsupported function was attempted when users try to check unread messages with Unified Messaging Trial Software.

Notes server software that is earlier than version 4.5 lacks support for accessing unread message information from a Notes server. Earlier versions only support API access to unread message information in local databases.

To resolve this lack of support, leave the “Notes Server” field blank, and type in a network mapped path (such as Z:\Notes\Data\Mail) to each user's mail file as if the file were local.

Notes limitations

Lotus has solutions for unread message problems documented in the Lotus Notes Knowledge Base. For details, see:

- Document 169936, “Are unread marks fixed in release 5?”
- Document 160731, “How do unread marks work in a Notes/Domino 4.x environment?”
- Document 179683, “Two common unread mark scenarios: new mail appears read and already opened mail appears unread”

Minimizing problems

You can minimize or often eliminate the problems described in this section. Do one or more of the following to resolve the most common problems:

- Confirm that users always access the same mail file replica as Unified Messaging Trial Software. If users access different replicas, unread message information may be inaccurate.
- If one of the replicas is a local replica (on a client), use the "Replicator_sync_unread=-1" setting in the Notes.ini file on that client. Doing so forces unread synchronization during each replication and minimizes errors.
- Access all replicas frequently. If users wait long periods of time between accessing a given replica, older unread entries in the Notes journal file may be overwritten and lost before replayed to other replicas.
- Avoid using the "Mark all read" or "Mark all unread" settings when using very large mail files (over 1,000 documents) with multiple replicas, because the Notes journal file does not track these unread changes to other replicas.
- When using multiple replicas, use the Notes R5 Workspace page to unstack replica icons. Select two of the replicas and force replication of the unread tables by clicking the Edit>Unread Marks>Exchange Unread Marks menus. This sets up a manual process, but is more powerful than the "Replicator_sync_unread=-1" setting, because it allows unread replication between multiple server based replicas.

APPENDIX

Voice boards

Proline 2V voice board	22
Dialogic D/41H ISA voice board.....	24
Dialogic D/41E PCI voice board	26
Dialogic D/41ESC voice board.....	28
Dialogic D/120JCT-LS voice board	30
Dialogic D/160SC-LS voice board	32
Dialogic D/240PCI-T1 voice board.....	35

Proline 2V voice board

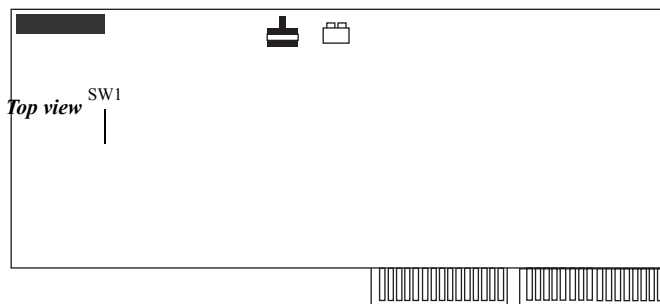
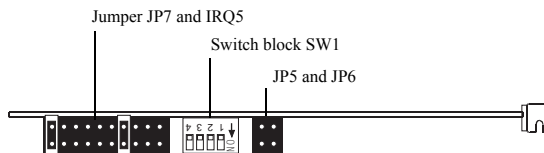

Side view

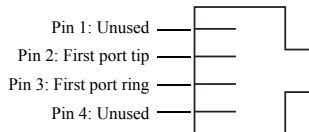
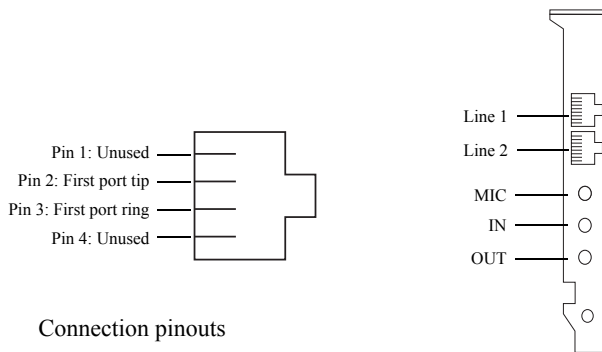

Connection pinouts

The Proline 2V uses RJ-14 connectors.

Voice board backplate











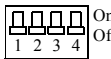



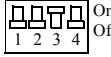

Hardware settings

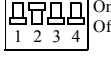
Do the following procedures as you install voice boards.

To set switch block SW1 and jumpers JP5, JP6, and JP7

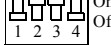
The switch block SW1 and jumper JP6 settings identify the voice board's memory address, which in turn specifies which voice messaging ports are on which board. The jumper JP7 setting specifies which board is in the first slot.

- 1 Set SW1 switches on each board as shown below.
- 2 Set jumpers JP5, JP6, and JP7 as shown below.

	SW1	JP5	JP6	JP7	Memory address
First board Ports 1–4	 On Of				<i>D0000</i>
Second board Ports 5–8	 On Of				<i>D2000</i>
Third board Ports 9–12	 On Of				<i>D4000</i>
Fourth board Ports 13–16	 On Of				<i>D6000</i>



To set jumper JP1 (IRQ setting)

- Set jumper JP1 on all boards to position 4, IRQ 5, as shown in the diagram at left.

Dialogic D/41H ISA voice board

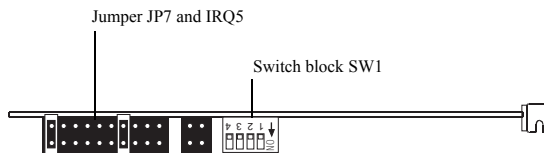

Top view

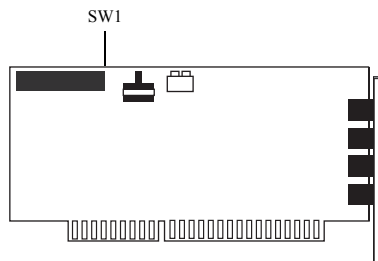

Side view

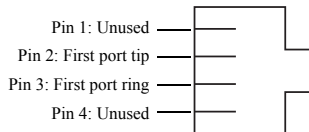

Connection pinouts

The D/41H uses RJ-11 connectors.

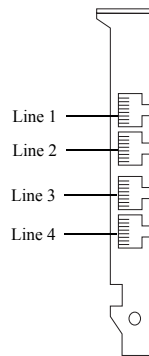

Voice board backplate











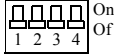





Hardware settings

Do the following procedures as you install voice boards.

To set switch block SW1 and jumpers JP5, JP6, and JP7

The switch block SW1 and jumper JP6 settings identify the voice board's memory address, which in turn specifies which voice messaging ports are on which board. The jumper JP7 setting specifies which board is in the first slot.

- 1 Set SW1 switches on each board as shown below.
- 2 Set jumpers JP5, JP6, and JP7 as shown below.

	SW1	JP5	JP6	JP7	Memory address
First board Ports 1–4	 On Off				<i>D0000</i>
Second board Ports 5–8	 On Off				<i>D2000</i>
Third board Ports 9–12	 On Off				<i>D4000</i>
Fourth board Ports 13–16	 On Off				<i>D6000</i>



To set jumper JP1 (IRQ setting)

- Set jumper JP1 on all boards to position 4, IRQ 5, as shown in the diagram at left.

Dialogic D/41E PCI voice board

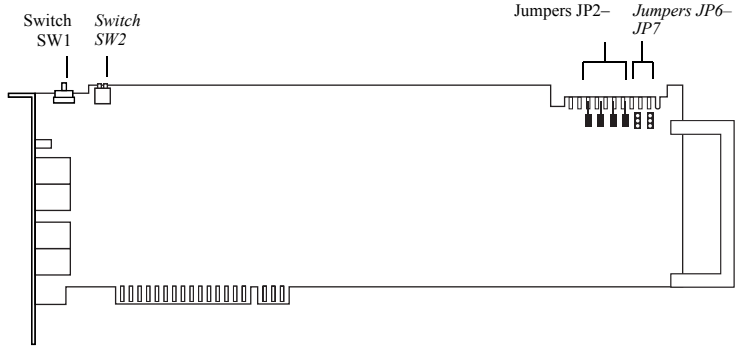

Side view

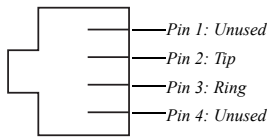

Connection pinouts

The D/41E PCI uses
RJ-11 connectors.

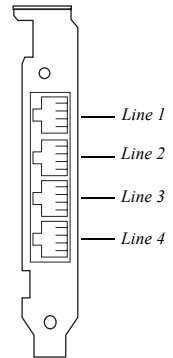

Voice board backplate

Hardware settings

Do the following procedures as you install voice boards.

To set the SW1 switch

- For each Dialogic PCI voice board that has a rotary switch, set the rotary switch to a unique value starting with 1 and continuing in sequence.

For example, set the rotary switch on the first three PCI voice boards in the Reception server as shown below. This is also the order in which you install the boards in the server.

First PCI board 

Second PCI board 

Third PCI board 

To set switch block SW2

- Set SW2 switches to “Off” on all boards.

To set jumpers JP2 to JP7

- Set jumpers JP2 to JP5 to “Off” on each board. For jumpers JP6 and JP7, install shunts on the top two pins (1 and 2).

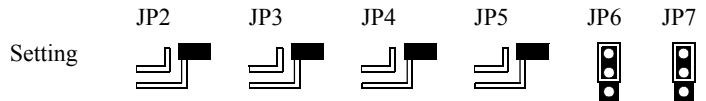

Dialogic D/41ESC voice board

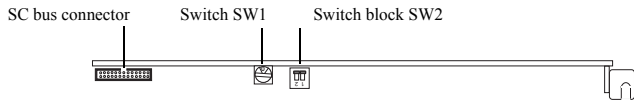

Top view

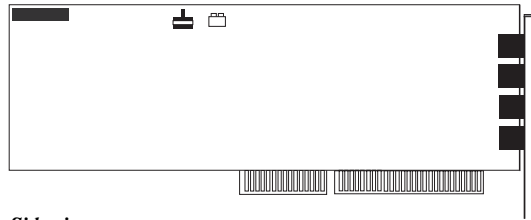

Side view

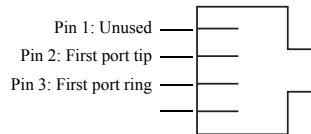

Connection pinouts

The D/41ESC uses RJ-11 connectors.

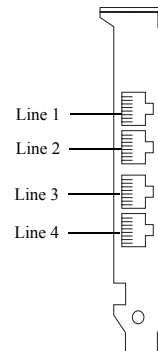

Voice board backplate

Hardware settings

Do the following procedures as you install voice boards.

To set the SW1 switch

- For each Dialogic ISA voice board that has a rotary switch, set the rotary switch to a unique value starting with 0 and continuing in sequence.

For example, set the rotary switch on the first three ISA voice boards in the Reception server as shown below. This is also the order in which you install the boards in the server.

First ISA board 

Second ISA board 

Third ISA board 

To set switch block SW2

- Set SW2 switches to “Off” on all boards.

Dialogic D/120JCT-LS voice board

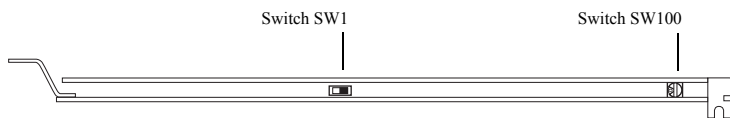

Top view

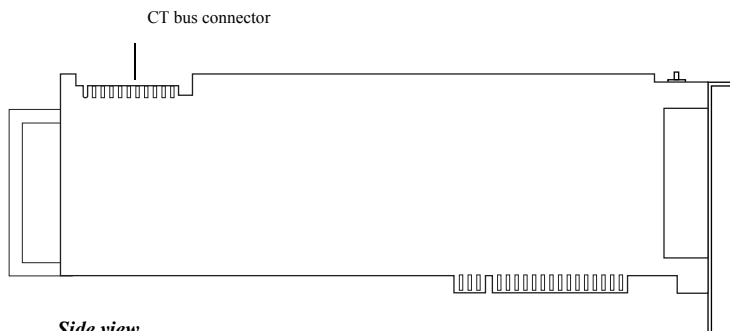

Side view

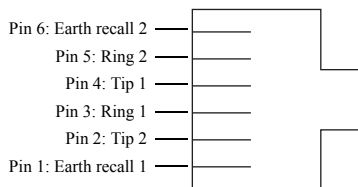

Connection pinouts

The D/120JCT-LS uses RJ-25 connectors.

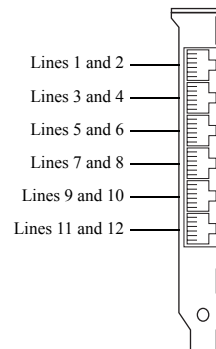

Voice board backplate

Hardware settings

Do the following procedures as you install voice boards.

To set the SW100 switch

- For each Dialogic PCI voice board that has a rotary switch, set the rotary switch to a unique value starting with 1 and continuing in sequence.

For example, set the rotary switch on the first three PCI voice boards in the Reception server as shown below. This is also the order in which you install the boards in the server.

First PCI board 

Second PCI board 

Third PCI board 

To set the SW1 switch

- Set switch SW1 to “On hook” on all boards as shown below.

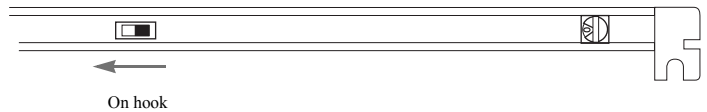

Dialogic D/160SC-LS voice board



Top view

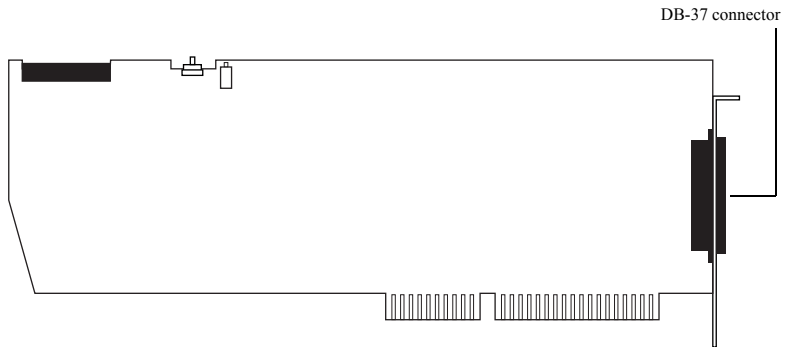

Side view

Connection pinouts

The D/160SC-LS uses a DB-37 connector. See the table on the next page for pinout information.

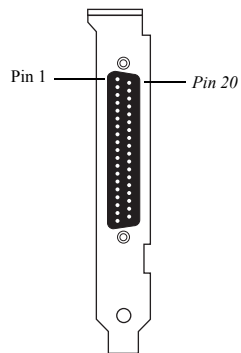

DB-37 pinouts

Line number	Tip connection	Ring connection
1	Pin 1	Pin 18
2	Pin 2	Pin 19
3	Pin 3	Pin 20
4	Pin 4	Pin 21
5	Pin 5	Pin 22
6	Pin 6	Pin 23
7	Pin 7	Pin 24
8	Pin 8	Pin 25
9	Pin 9	Pin 26
10	Pin 10	Pin 27
11	Pin 11	Pin 28
12	Pin 12	Pin 29
13	Pin 13	Pin 30
14	Pin 14	Pin 31
15	Pin 15	Pin 32
16	Pin 16	Pin 33

- u Pin 37 is the ground.
- u Pins 17, 34, 35, and 36 are unused.

Continued

Hardware settings

Do the following procedures as you install voice boards.

To set the SW100 switch

- For each Dialogic ISA voice board that has a rotary switch, set the rotary switch to a unique value starting with 0 and continuing in sequence.

For example, set the rotary switch on the first three ISA voice boards in the Reception server as shown below. This is also the order in which you install the boards in the server.

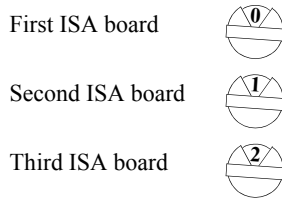

To set the SW4 switch

- Set switch SW4 to “Off hook” on all boards as shown below.

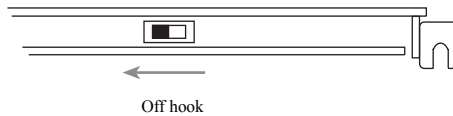

Dialogic D/240PCI-T1 voice board



Top view

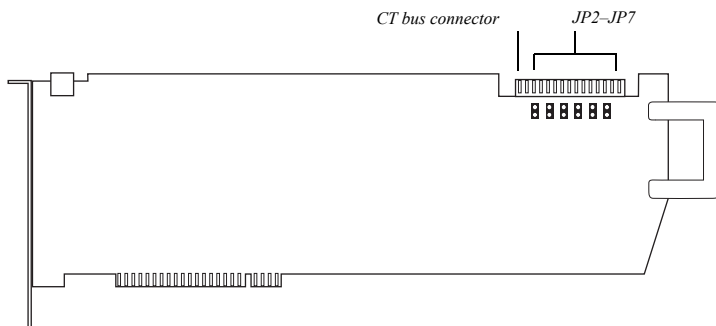

Side view

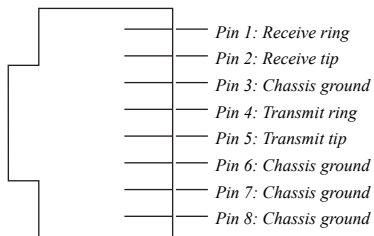

Connection pinouts

The D/240PCI-T1 uses an RJ-48C connector.

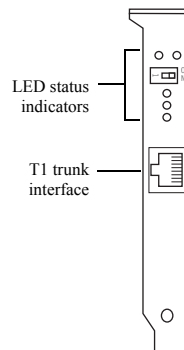

Voice board backplate

Hardware settings

Do the following procedures as you install voice boards.

To set the SW100 switch

- For each Dialogic PCI voice board that has a rotary switch, set the switch to a unique value starting with 1 and continuing in sequence. For example, set the switch on the first three PCI voice boards in the Reception server as shown below. Install the boards in the server in the same order.







First PCI board 

Second PCI board 

Third PCI board 

To set jumpers JP2 to JP7

- Set jumpers JP2 to JP5 to “Off” on each board. For jumpers JP6 and JP7, install shunts on the top two pins (1 and 2).

Setting      

LED status indicators

The D/240PCI-T1 includes the following status indicators.

Color	Lit
Green	The board is powered up and receiving an external signal
Yellow	Loss of frame synchronization at far end of external network
Red	Loss of frame synchronization on incoming line from external network

INDEX

telephone system. *See* phone system

A

Absence greeting field 26

Access Control List

 setup ID with Manager access 28

 troubleshooting 38

accessing NAB 28

automated attendant options 20

automatic startup 12

B

blind transfer 27

C

call forwarding. *See* call transfer

Call Pursuit 23, 26

Call screening field 27

call transfer

 blind 27

 default settings 20– 21

 integration options 15

 setup for phone extension 27

 supervised 27

Canonical name field

 setup 25

 troubleshooting 37

card. *See* voice boards

changing Unified Messaging settings 20

checklist for installation 7

computer requirements 7

Confirm deletions field 27

connecting Unified Messaging and the phone system 17

Conversation monitoring field 27

D

D/120JCT-LS voice board 50

D/160SC-LS voice board 52

D/240PCI-T1 voice board 55

D/41E PCI voice board 46

D/41ESC voice board 48

D/41H ISA voice board 44

DECTalk

 installation 32

 languages setup 33

default settings for Unified Messaging 20

Dialogic System Software disc

 installing software 11

 IRQ setup 9

 voice board setup 11

Dialogic voice boards 9, 41

Dialogic WAV drivers, installing 12

DID (direct inward dial) options 22

directory assistance settings 20

Domino

 directory path setup 8

 ID setup 28

 Manager access setup 28

E

easy message access, integration overview 15

errors. *See* troubleshooting

extension setup 26

F

field descriptions for PhoneSoft Person form 25

forwarding calls. *See* call transfer

G

Greeting field 26

H

hardware requirements 7

hunt groups, setup 15

I—K

- ID setup for Notes or Domino 28
- installing
 - checklist for 7
 - DECTalk 32
 - Dialogic software 11
 - Dialogic WAV drivers 12
 - languages for TTS 32
 - overview 6
 - Play By Phone and Play Multimedia 34
 - RealSpeak 31
 - system requirements for 7
 - Unified Messaging 18
 - upgrade software 6
 - voice board settings 41
 - voice boards 9
- integration, phone system overview 14
- IRQ setup 9
- ISA voice boards 9, 41

L

- languages
 - installing DECTalk 32
 - multiple language setup 33
- Log missed calls field 27

M

- Machine name field 27
- Mail address field 25
- Mail file field 26
- Mail Server field 25
- Mailbox number field 26
- Mailbox password field 26
- Manager access, setting for Notes 28
- menu and prompt settings 21
- message sort, changing 23
- message waiting indication (MWI)
 - integration overview 15
 - options 21

- multiple extension setup 26
- multiple extensions setup 23
- multiple language setup 33
- MWI state field 27

N

- NAB (Name and Address Book) setup 24– 28
- Name recording field 26
- Notes
 - directory path setup 8
 - ID setup 28
 - Manager access setup 28
 - troubleshooting 39
- NT service setup 18
- Numeric page string field 27

O

- opening Unified Messaging 19
- operator settings 20

P—Q

- Pager address field 27
- path, system path setup 8
- PCI voice boards 9, 41
- Person form PhoneSoft field descriptions 25
- Phone # field 30
- Phone extension fields 26– 27
- phone lines setup 30
- Phone Server, starting 19
- phone system
 - connecting to Unified Messaging 17
 - hunt group setup 15
 - setup 15
 - setup overview 14
 - testing setup 16
- PhoneSoft form field descriptions 25
- Play By Phone setup 34
- Play Multimedia setup 34
- problem solving
 - minimizing errors 40
 - unread message information 37
- Proline 2V voice board 42
- prompt and menu settings 21
- PS Desktop setup 34
- PSF Names (sample database) setup 25

R

- RealSpeak installation 31
- recording conversations, Conversation monitoring field 27
- replica NAB database
 - setup 24
 - troubleshooting 38, 40

S

- sample database setup 25
- setting up
 - Access Control List for Unified Messaging 28
 - access to NAB 28
 - field descriptions for PhoneSoft 25

- hunt groups 15
- languages 33
- mail database or NAB 24
- menus and prompts 21
- multiple languages 33
- Notes ID 28
- phone lines 30
- phone system integration 15
- Play By Phone 34
- Play Multimedia 34
- replica NAB database 24
- Unified Messaging as NT service 18
- users 24– 28
- voice boards 11

- signaling, SMDI setup 22
- SMDI support and setup 22
- software requirements 7
- software update 6
- sort order, changing for messages 23
- Spelled last name field 25
- starting Phone Server 19
- startup, automatic 12
- supervised transfer 27
- system path, setup and confirm 8
- system requirements 7

T

- testing
 - phone system setup 16
 - voice board setup 13
- transferring calls. *See* call transfer
- troubleshooting
 - Access Control List 38
 - mail file open conflict 38
 - minimize problems 40
 - Notes software 39
 - read and unread messages 37
 - replica NAB database 38
 - view problems 38
- TTS (text to speech)
 - installing languages for DECTalk 32

- installing RealSpeak 31
- multiple language setup 33

U

- Unified Messaging
 - changing settings 20
 - connecting to phone system 17
 - installing 18
 - SMDI support 22
 - starting 19
- unread message information, troubleshooting 37
- updating software 6
- upgrading from E-Mail Reader 6

V

- View selection field 27
- voice boards
 - D/120JCT-LS 50
 - D/160SC-LS 52
 - D/240PCI-T1 55
 - D/41E PCI 46
 - D/41ESC 48
 - D/41H ISA 44
 - illustrations 41
 - installing 9
 - Proline 2V 42
 - settings 41
 - setup 11
 - supported list 9
 - testing setup 13

W—Z

- WAV driver installation 12

